

# Service Schematics



RM-551/RM-559



## IMPORTANT

This document is intended for use by authorized Nokia service centers only. Please use the document together with other documents such as the Service Manual and Service Bulletins.

## Version information

While every effort has been made to ensure that the document is accurate, some errors may exist. Please always check for the latest published version for this document.

If you find any errors in the document please send email to:  
TrainingAndVendorDevelopment@nokia.com

## Version history

1.0	First Approved version
2.0	Descriptive labels added

Copyright © Nokia

This material, including documentation and any related computer programs is protected by copyright, controlled by Nokia. All rights are reserved. Copying, including reproducing, modifying, storing, adapting or translating any or all of this material requires the prior written consent of Nokia. This material also contains company confidential information, which may not be disclosed to others without the prior written consent of Nokia.

## Measurements

All measurements were made using the following equipment:

Nokia repair SW	: Phoenix 2009.20.011.39237
Oscilloscope	: PicoScope 3206
Spectrum Analyzer	: Advantest R3162
Multimeter	: Fluke 175

The measurement points in the schematics are linked to the oscillograms on the signal overview page. The links cycle between the measurement point in the schematics, the oscillogram and the measurement point in the component finder.

## Table of Contents

Front page	1
RAPIDO, HS USB, Sensors	2
Combo Memory, eMMC	3
BETTY, AVILMAS, Battery, SIM	4
Audio, AV Connector	5
Camera, Upper Flex Connector	6
TV-Out, Display	7
Keyboard I/F, Keyboard Backlighting	8
BTHFM, WLAN, GPS	9
RF part	10
Signal Overview	11
Component Finder	12

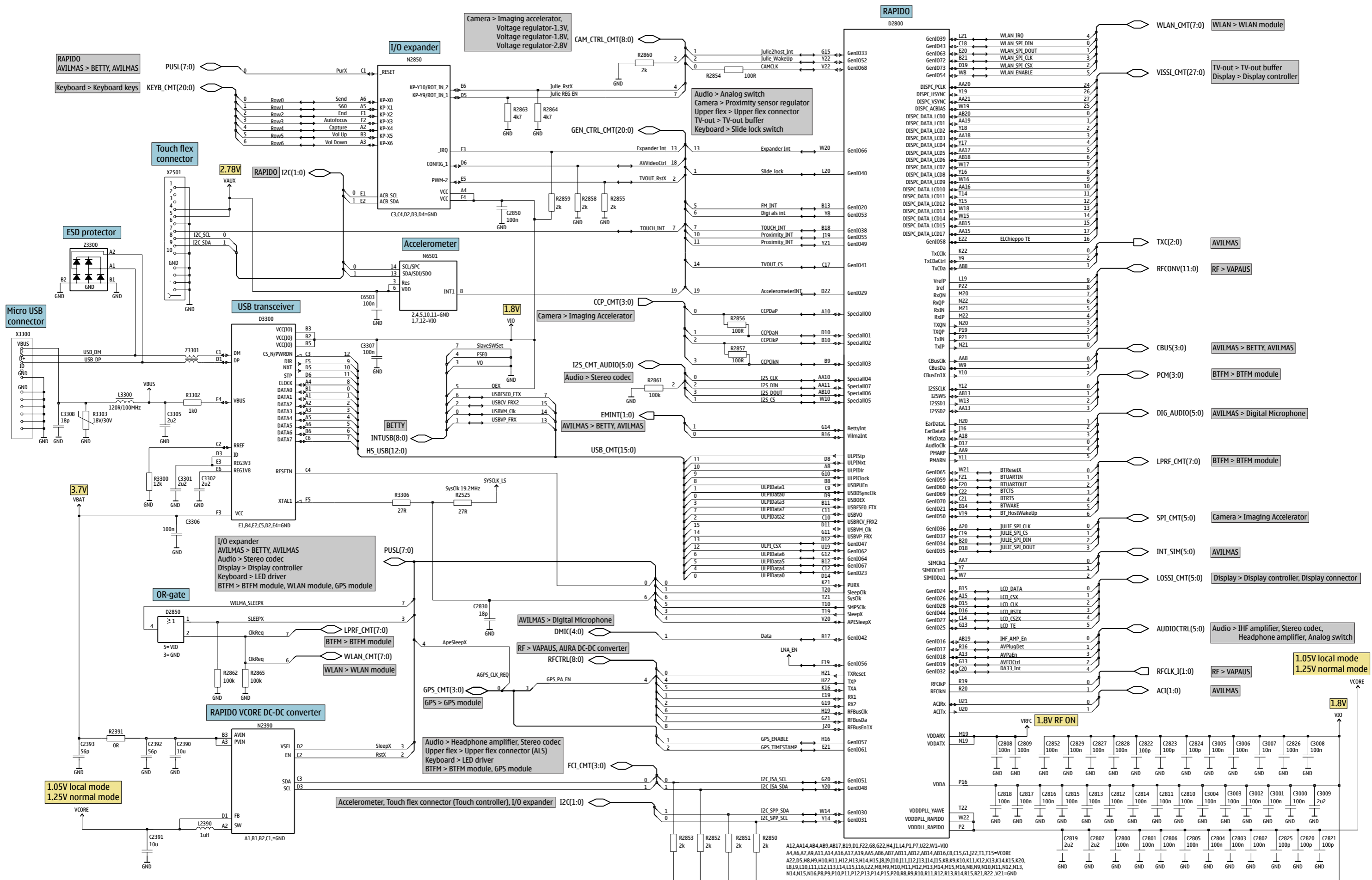

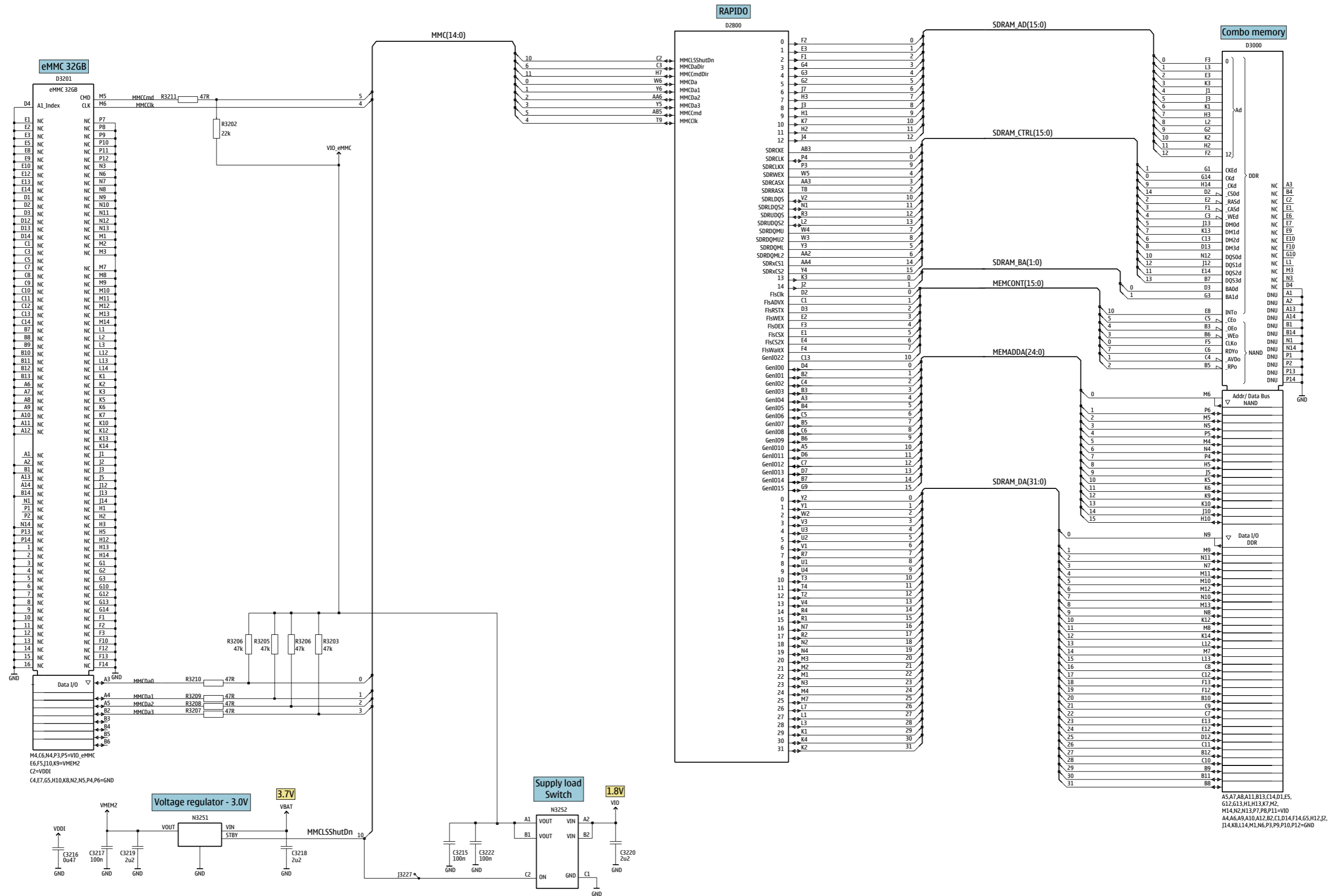

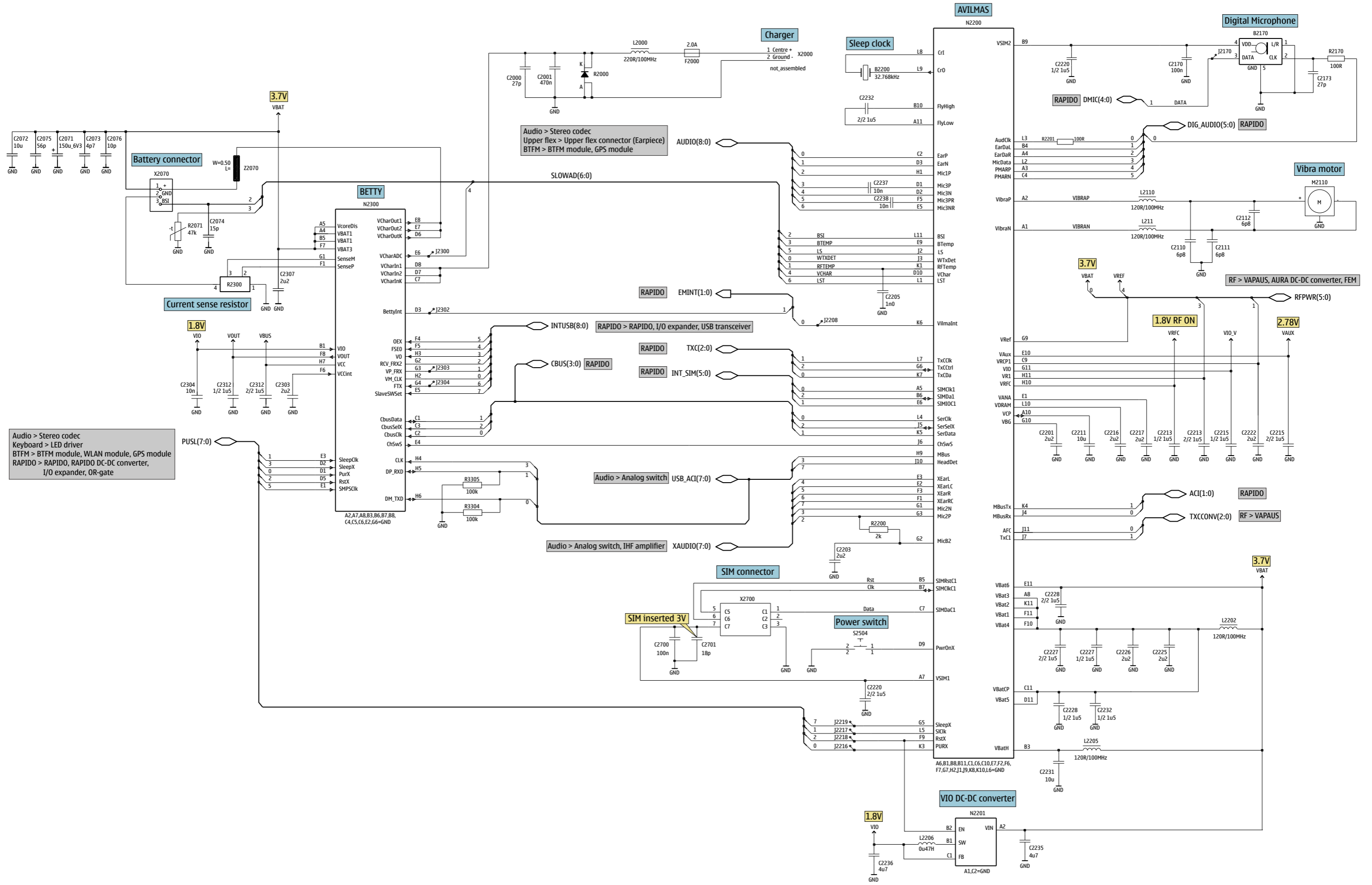

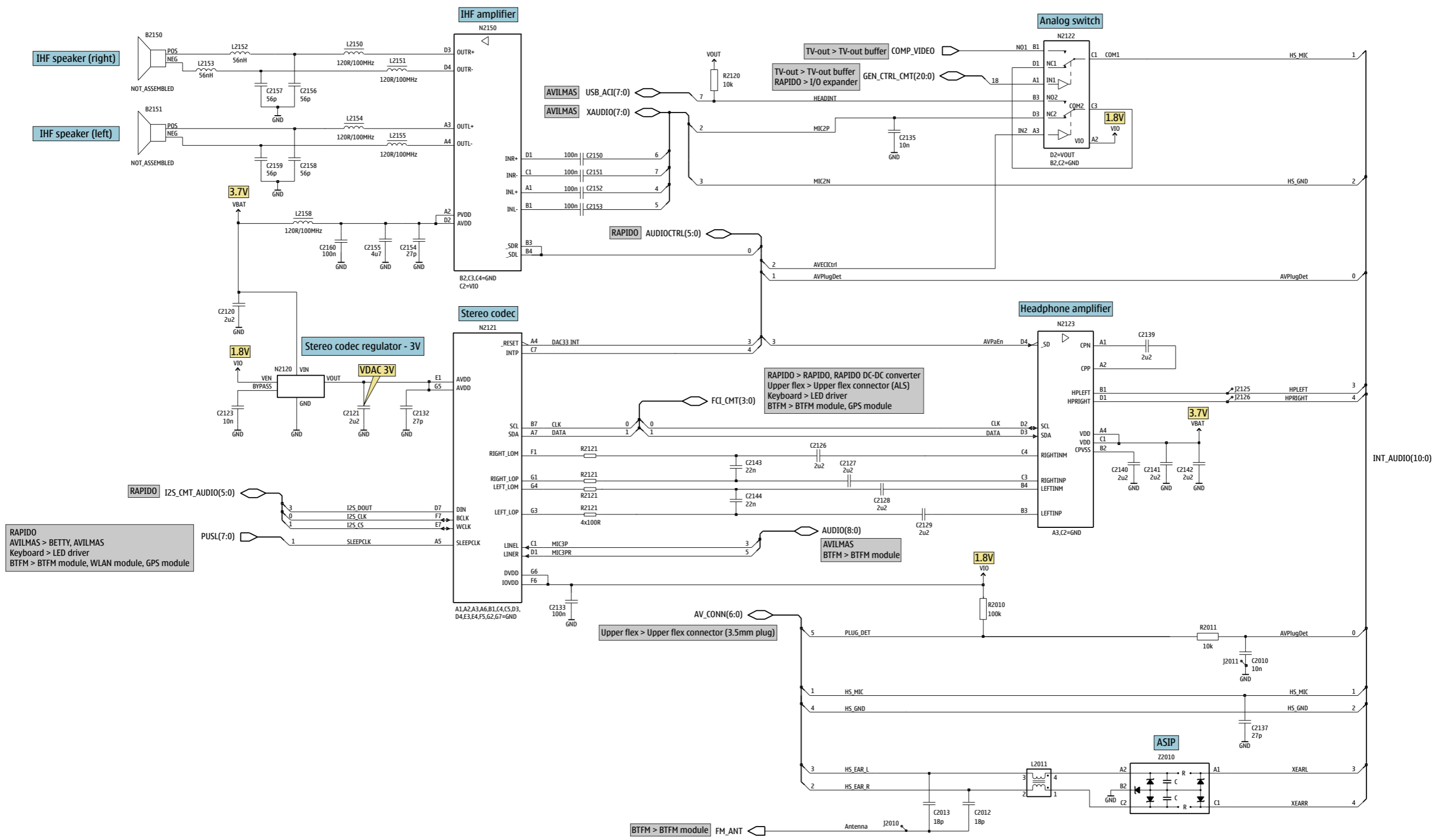



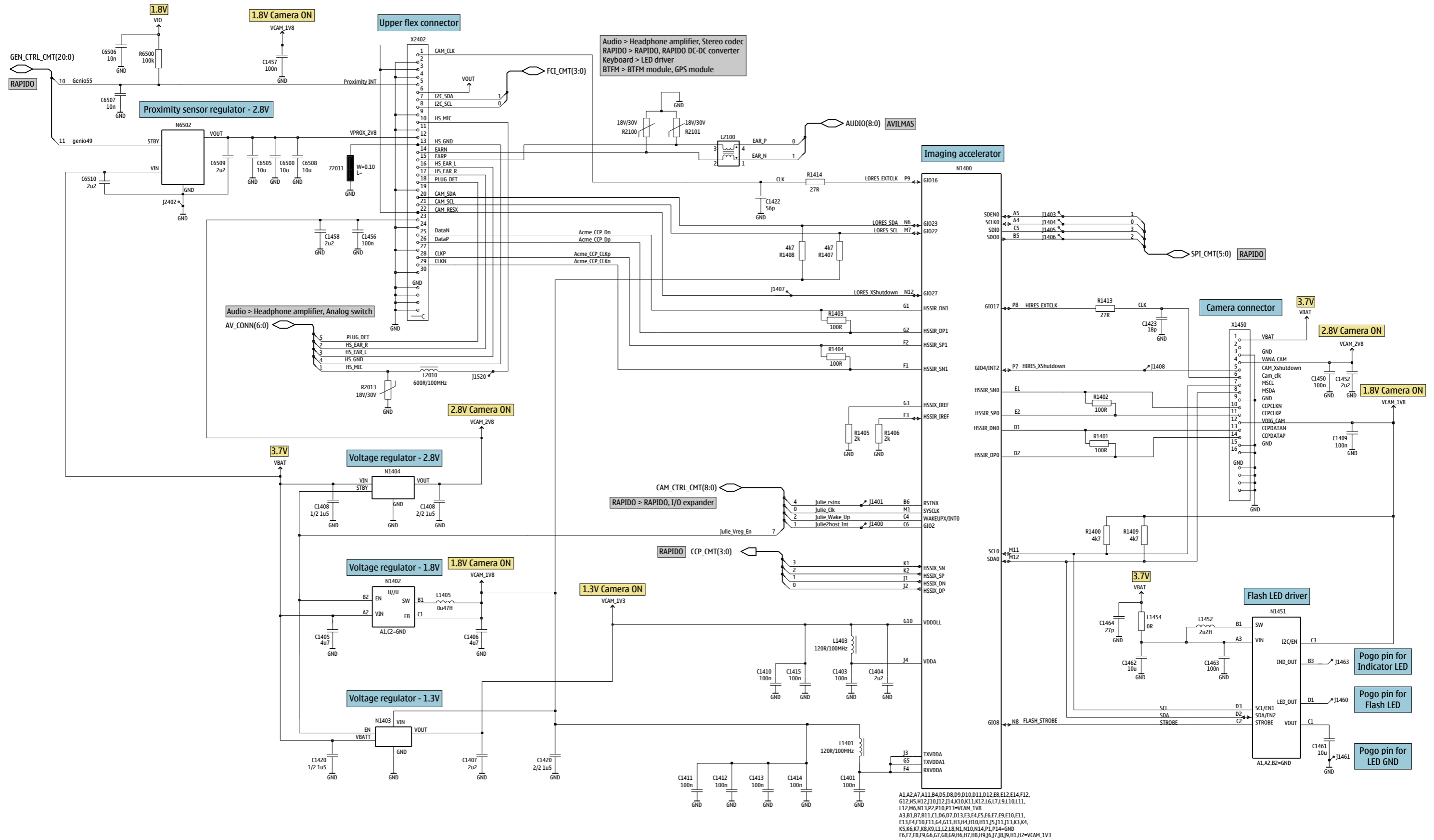

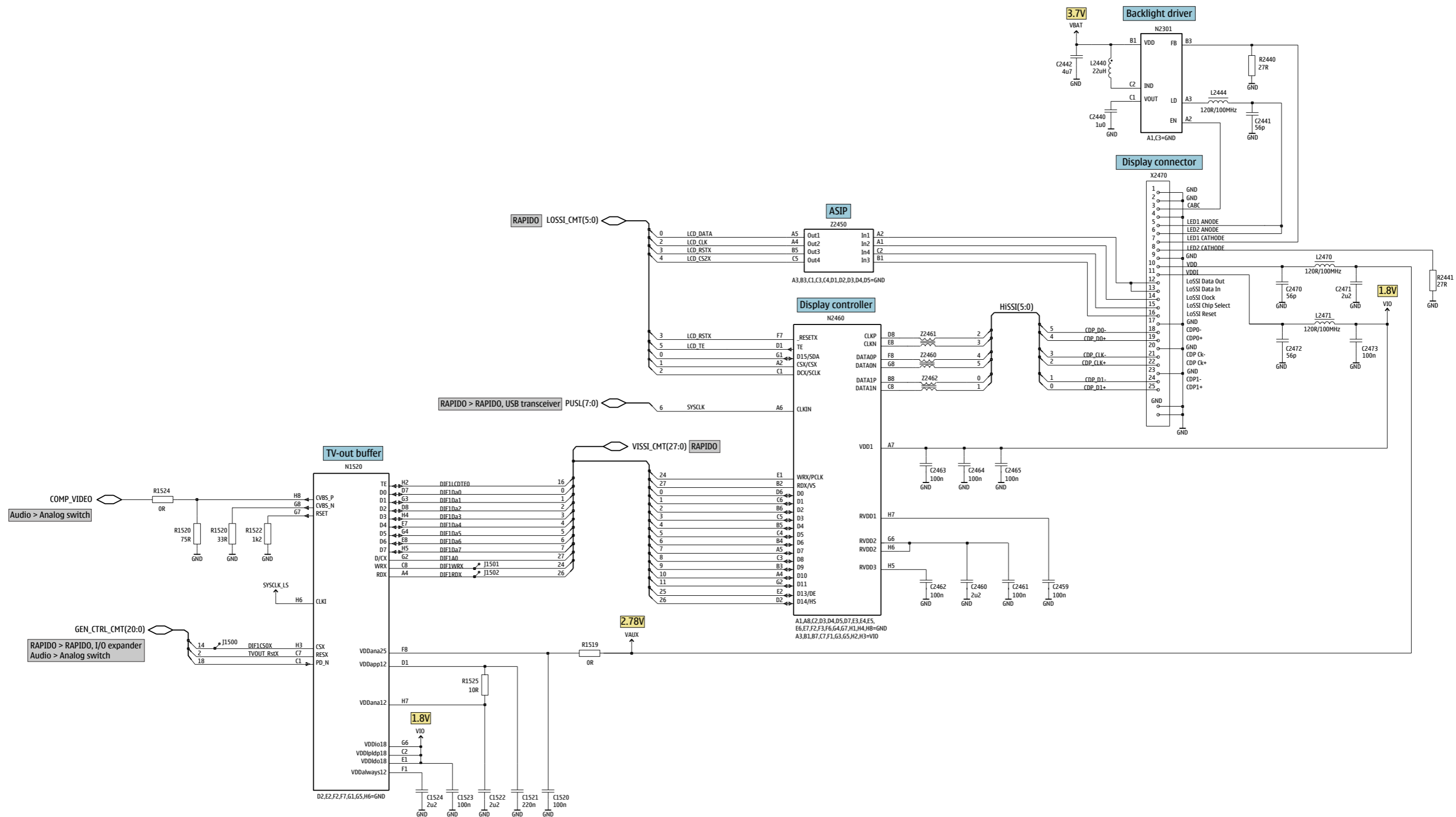

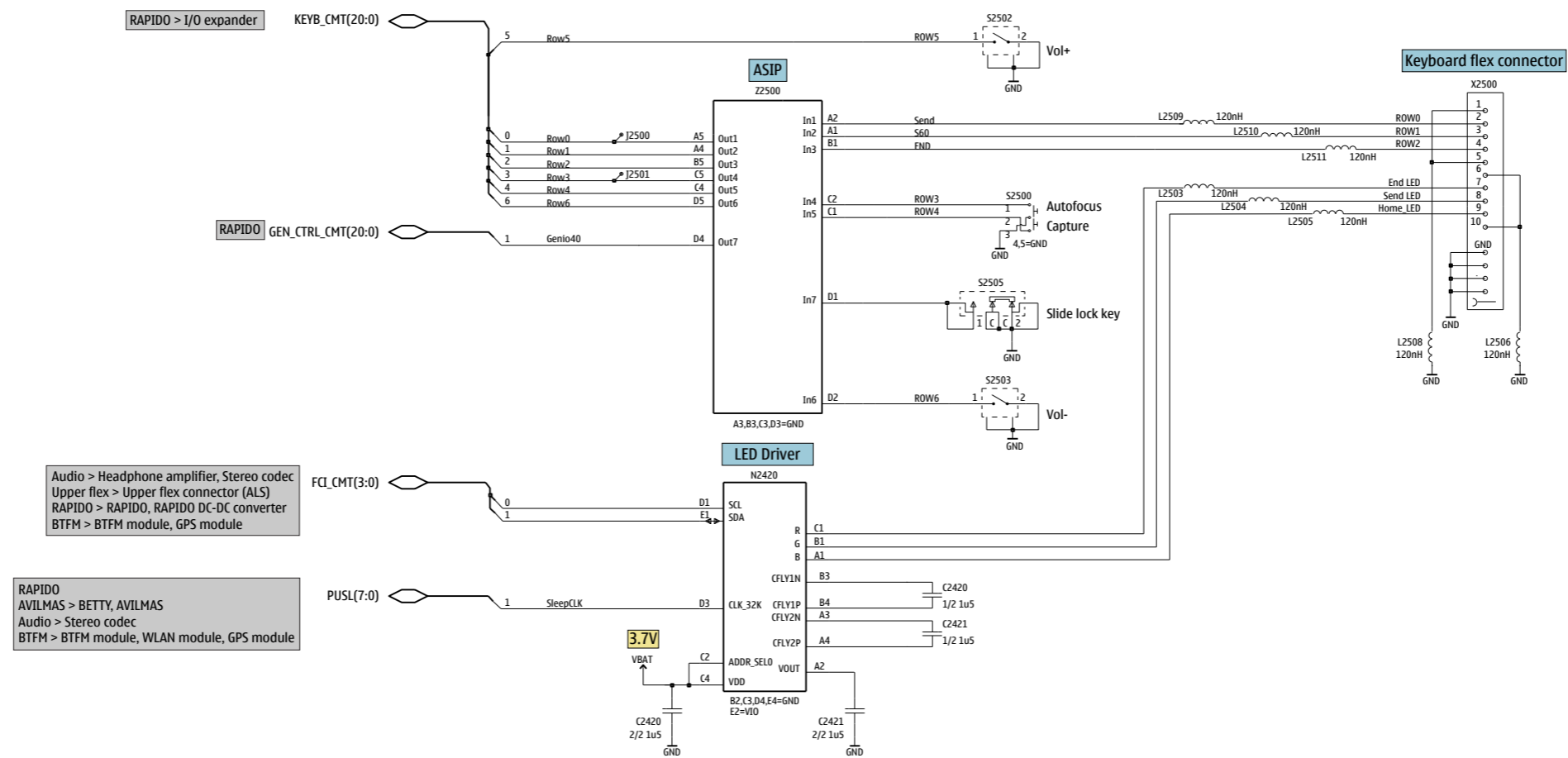



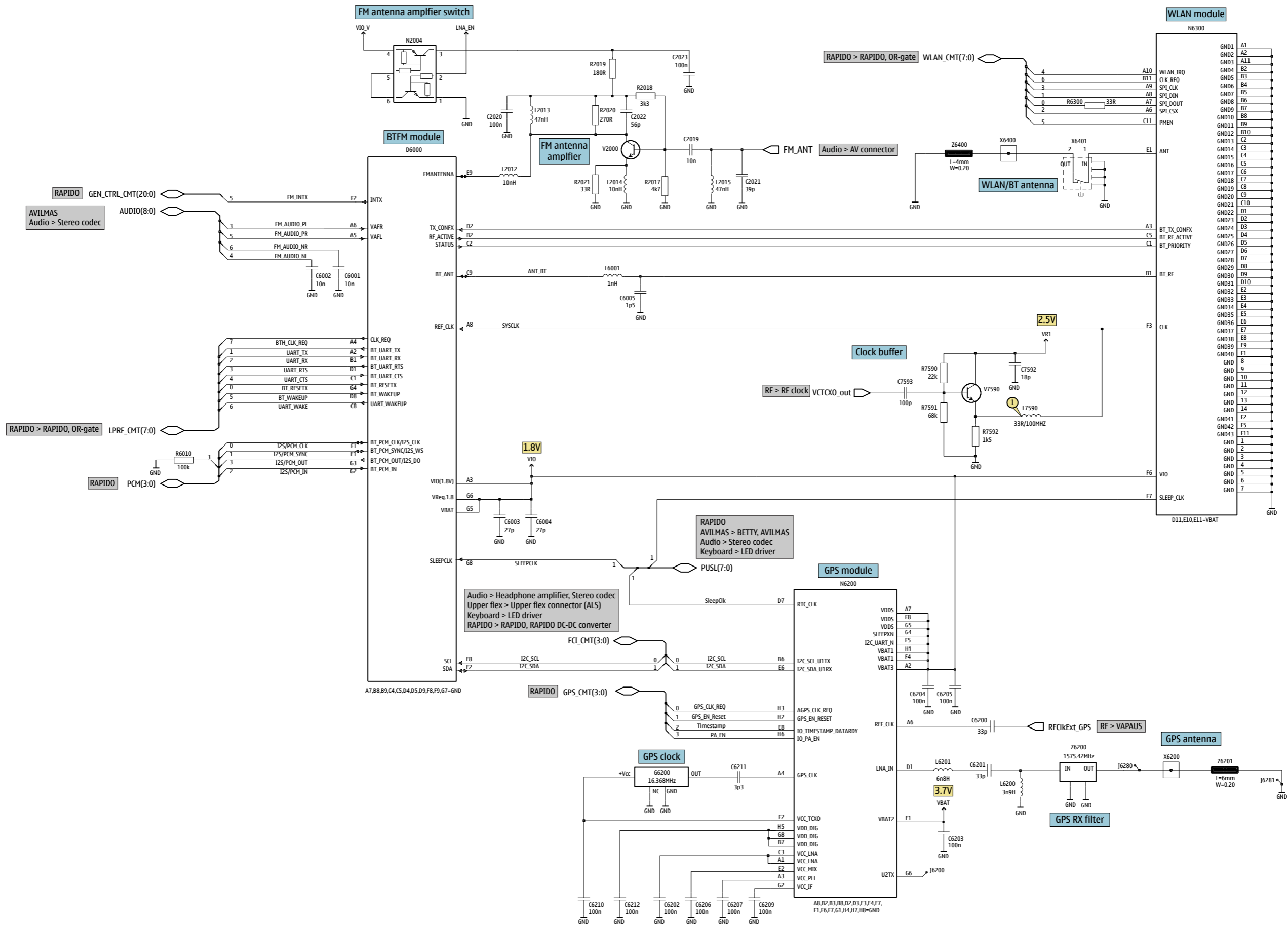

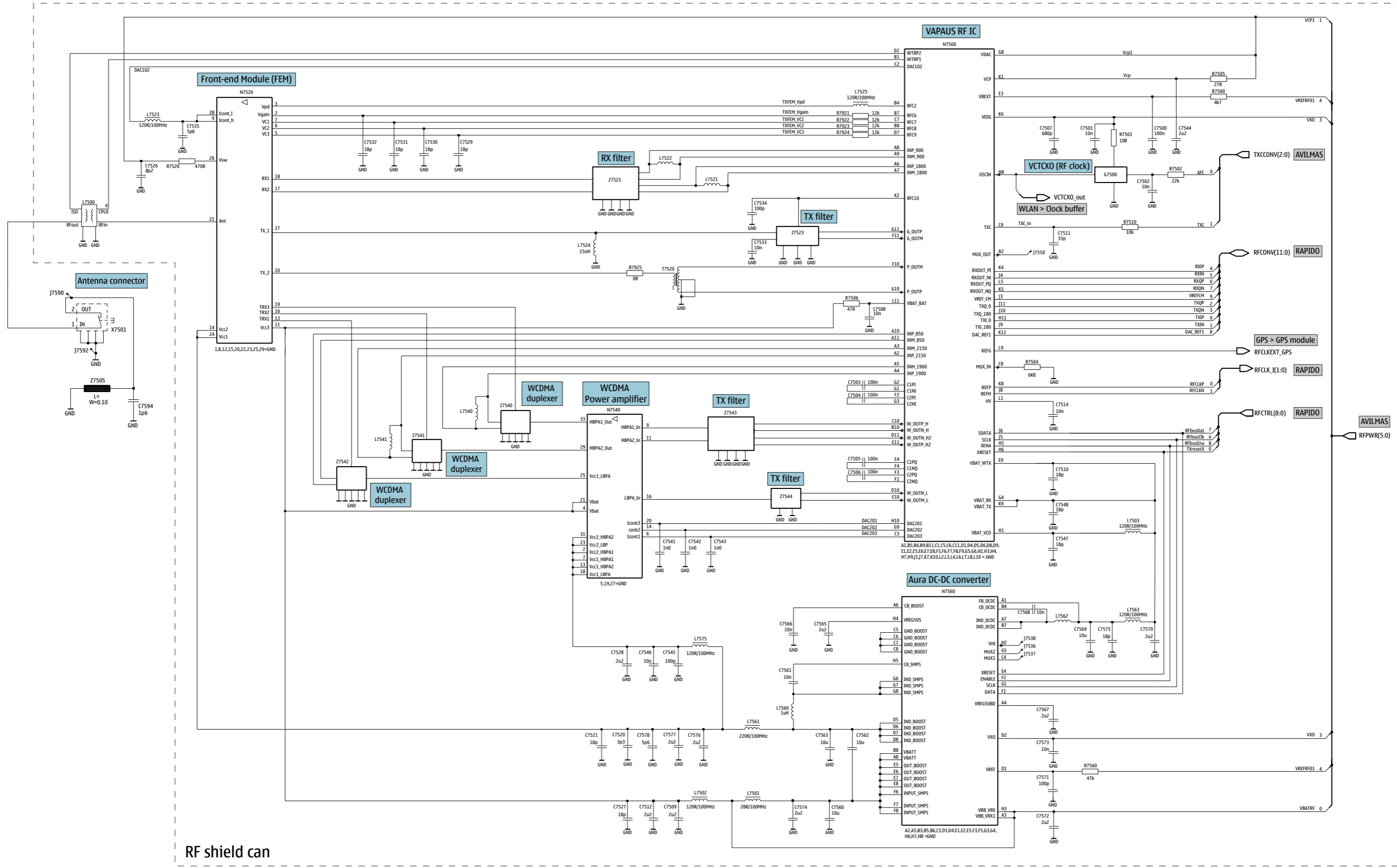

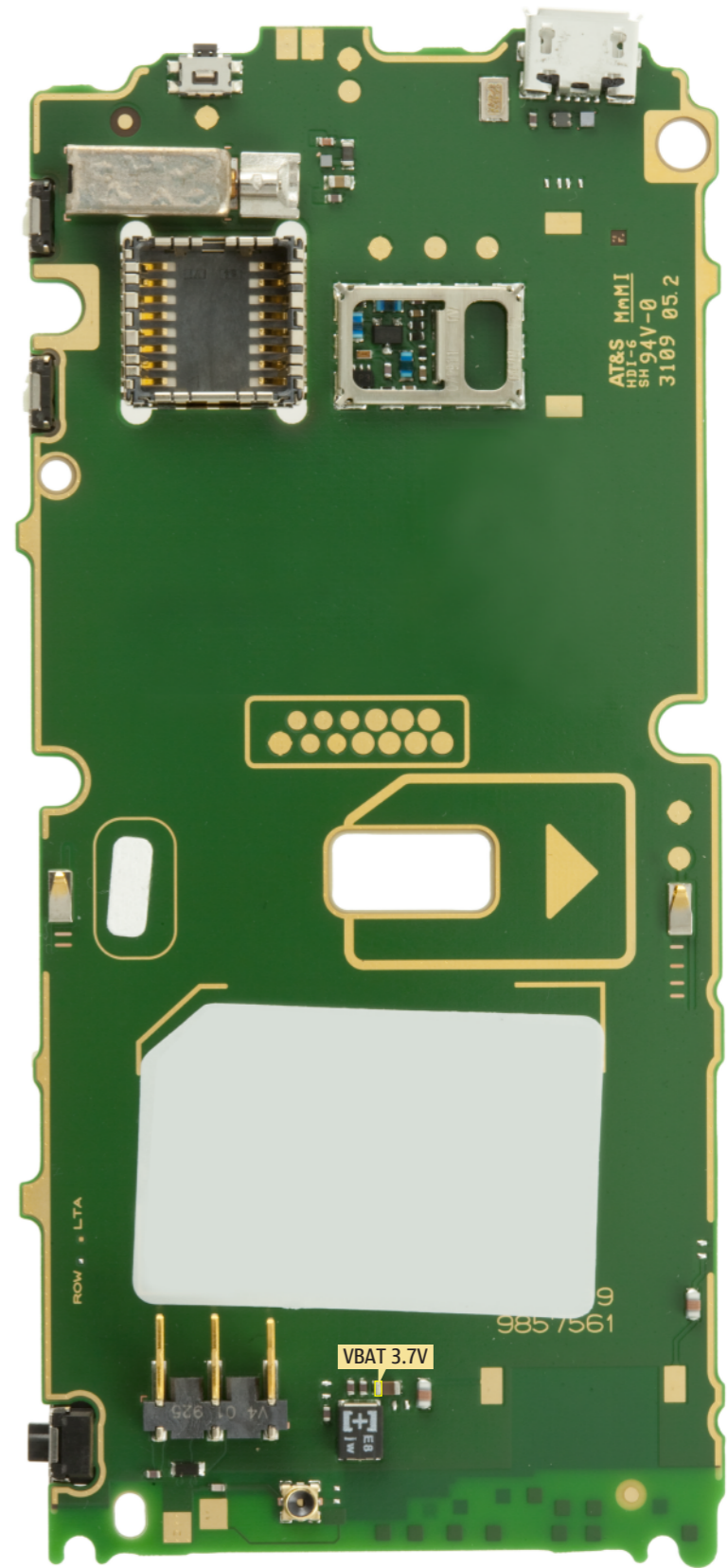
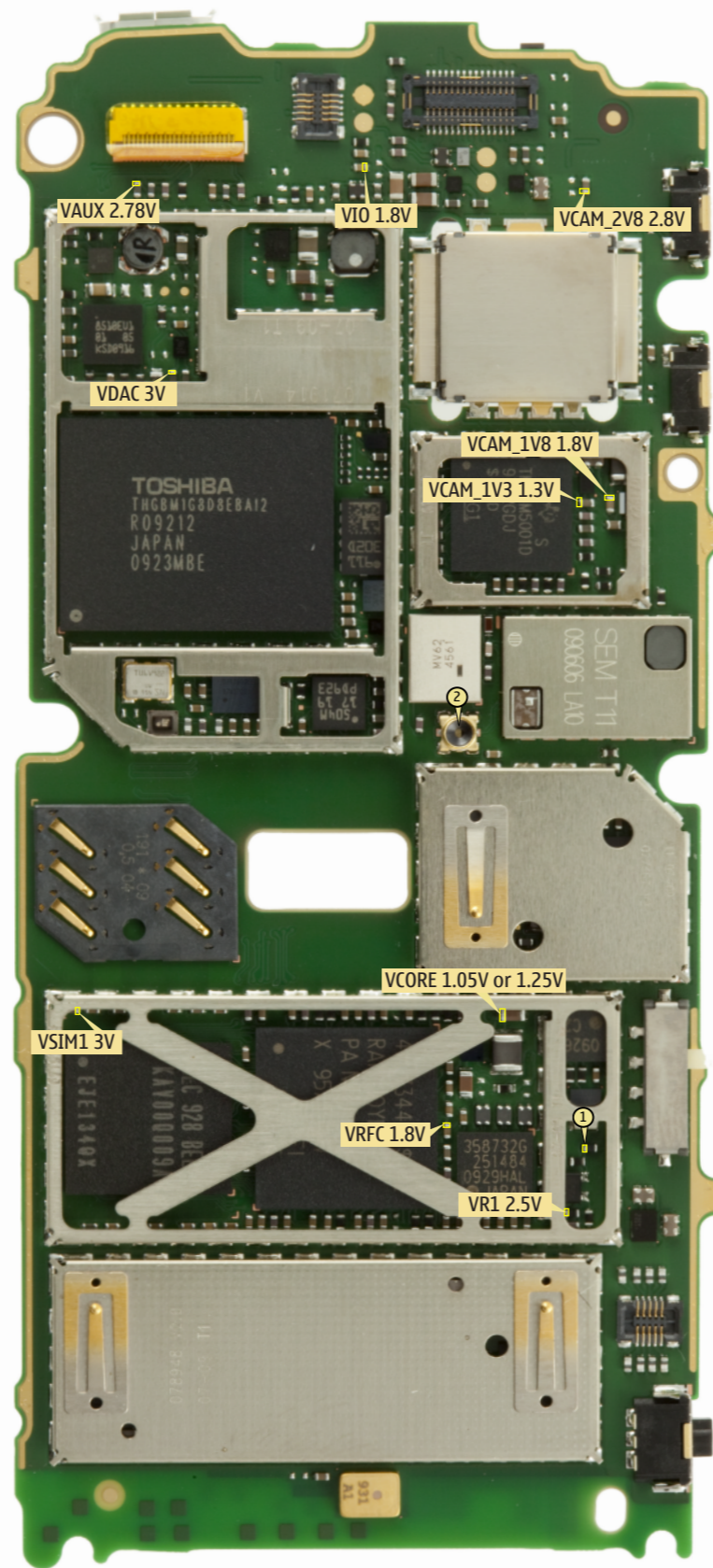
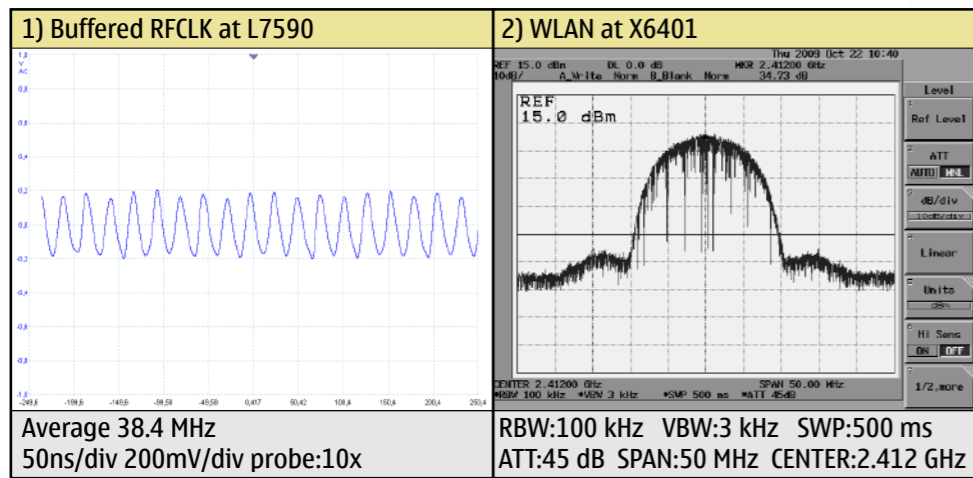



<b>A</b>	C2076	I2	C2312	G10	C3003	C5	C7511	H5	L1401	F14	L7590	I6	R2017	E17	R7505	H3		
A1400	H15	C2110	I11	C2390	G7	C3004	B5	C7512	F2	L1403	G14	<b>M</b>	R2018	E17	R7506	F5		
A1451	E17	C2111	I11	C2391	H8	C3005	D8	C7514	H3	L1405	I15	M2110	H19	R2019	E16	R7510	H5	
A2300	H10	C2112	H11	C2420	J5	C3006	C8	C7520	C3	L1452	E18	<b>N</b>	R2020	E17	R7520	D5		
A2800	E7	C2120	C16	C2421	I6	C3007	D5	C7521	D3	L1454	E18	N1400	G15	R2021	F18	R7560	C4	
A3201	D15	C2121	C16	C2440	B18	C3008	B8	C7526	E5	L2000	F19	N1402	I15	R2071	I12	R7590	H5	
A7500	E3	C2123	C17	C2441	B18	C3009	B5	C7527	C3	L2010	F21	N1403	H15	R2100	E19	R7591	I5	
<b>B</b>	C2126	E16	C2442	C18	C3100	F12	C7528	E2	L2011	G19	N1404	H19	R2101	F19	R7592	H6		
B2170	F2	C2127	E16	C2459	G5	C3215	E16	C7529	D5	L2012	F17	N1451	D18	R2120	F16	R7921	G4	
B2200	H10	C2128	E17	C2460	H5	C3216	E14	C7530	D5	L2013	E17	N1520	B17	R2121	E17	R7922	G4	
<b>C</b>	C2129	E17	C2461	H5	C3217	E13	C7531	D5	L2014	F17	N2004	F17	R2170	F8	R7923	G4		
C1401	F14	C2132	D16	C2462	G5	C3218	E13	C7532	D5	L2015	E17	N2120	C17	R2200	H11	R7924	G4	
C1403	G14	C2133	E17	C2463	G5	C3219	E13	C7533	D5	L2100	E19	N2121	D17	R2201	G8	R7925	G4	
C1404	H14	C2135	E16	C2464	G7	C3220	F15	C7534	G4	L2110	I11	N2122	E16	R2300	H2	<b>S</b>		
C1405	I15	C2137	F20	C2465	G5	C3222	F16	C7535	G3	L2111	I11	N2123	E17	R2391	G7	S2500	J2	
C1406	I15	C2139	E17	C2470	C19	C3301	F12	C7541	F5	L2150	G11	N2150	G11	R2440	B18	S2502	J19	
C1407	H15	C2140	F17	C2471	C19	C3302	E13	C7542	G4	L2151	G11	N2200	I10	R2441	C19	S2503	J16	
C1408	H19	C2141	F17	C2472	D19	C3305	F13	C7543	F3	L2152	E3	N2201	G9	R2525	E17	S2504	H21	
C1409	F17	C2142	E17	C2473	D19	C3306	E13	C7544	H3	L2153	A4	N2300	G10	R2850	J9	S2505	J7	
C1410	G14	C2143	E17	C2700	B8	C3307	E12	C7545	E5	L2154	G11	N2301	B18	R2851	I9	<b>T</b>		
C1411	G14	C2144	E17	C2701	B8	<b>C3308</b>	<b>C20</b>	C7546	F3	L2155	G11	N2390	G8	R2852	G8	T7520	G4	
C1412	F15	C2150	G10	C2800	D5	C6001	G11	C7547	H3	L2158	H10	N2420	I5	R2853	F8	<b>V</b>		
C1413	H14	C2151	H10	C2801	F8	C6002	G12	C7548	H4	L2202	I9	N2460	G6	R2854	F5	V2000	E17	
C1414	H15	C2152	G10	C2802	E5	C6003	G13	C7560	B4	L2205	I11	N2850	H8	R2855	H7	V7590	H6	
C1415	F14	C2153	G10	C2803	E8	C6004	F12	C7561	B4	L2206	G9	N3251	F13	R2856	E8	<b>X</b>		
C1420	I15	C2154	G11	C2804	G7	C6005	G13	C7562	B4	L2390	G8	N3252	F16	R2857	E8	X1450	H17	
C1422	H14	C2155	H11	C2805	E8	C6200	C13	C7563	B4	L2440	C18	N6200	D12	R2858	H7	X2060	D20	
C1423	H14	C2156	H11	C2806	E5	C6201	C12	C7565	B4	L2444	B18	N6300	I13	R2859	H7	X2070	H3	
C1450	I17	C2157	H11	C2807	G6	C6202	C12	C7566	B3	L2470	C19	N6501	F14	R2860	F5	X2402	G20	
C1452	H19	C2158	F10	C2808	G7	C6203	D12	C7567	B3	L2471	D19	N6502	G19	R2861	E5	X2470	C20	
C1456	H19	C2159	G11	C2809	G7	C6204	C12	C7568	B3	L2503	I3	N7500	H3	R2862	G11	X2500	I4	
C1457	H20	C2160	H11	C2810	D5	C6205	D12	C7569	B2	L2504	I3	N7520	D4	R2863	I14	X2501	E20	
C1458	H19	C2170	E2	C2811	D8	C6206	D12	C7570	H3	L2505	J3	N7540	F4	R2864	H14	X2700	C10	
C1461	E18	C2173	G8	C2812	E5	C6207	C12	C7571	C3	L2506	I3	N7560	B3	R2865	H11	X3300	C21	
C1462	E18	C2201	I9	C2813	E8	C6209	D12	C7572	B4	L2508	I5	<b>R</b>	R3202	E15	X6200	B9		
C1463	D18	C2203	H11	C2814	F8	C6210	D12	C7573	C3	L2509	J5	R1400	I14	R3203	E15	X6400	J10	
C1464	E18	C2205	H10	C2815	E5	C6211	C13	C7574	B3	L2510	I5	R1401	G15	R3204	E16	X6401	G12	
C1520	B16	C2211	J10	C2816	G7	C6212	D13	C7575	G2	L2511	I5	R1402	F15	R3205	E16	X7501	G2	
C1521	B16	C2213	H9	C2817	D5	C6500	F19	C7576	D5	L3300	F13	R1403	F14	R3206	E15	<b>Z</b>		
C1522	B17	C2215	I9	C2818	F5	C6503	F15	C7577	C5	L6001	G13	R1404	F15	R3207	F15	Z2010	G19	
C1523	B17	C2216	H9	C2819	G6	C6505	F19	C7578	C5	L6200	C12	R1405	F14	R3208	E15	Z2450	F14	
C1524	B17	C2217	I11	C2820	E8	C6506	F19	C7592	H6	L6201	D12	R1406	F15	R3209	F15	Z2460	H7	
C2000	F19	C2220	J10	C2821	F8	C6507	F19	C7593	H5	L7500	D3	R1407	I14	R3210	F15	Z2461	G7	
C2001	F19	C2222	J9	C2822	F5	C6508	F19	<b>C7594</b>	<b>H2</b>	L7501	B5	R1408	I14	R3211	E15	Z2462	G7	
C2010	E19	C2225	H9	C2823	D8	C6509	G19	<b>D</b>	L7502	C3	R1409	H14	R3300	F12	Z2500	H7		
C2012	F19	C2226	H9	C2824	D6	C6510	G19	D2800	E7	L7503	H2	R1413	H14	R3302	E13	Z3300	C20	
C2013	F20	C2227	H9	C2825	D5	C7500	G3	D2850	H11	L7521	G3	R1414	H14	R3303	F12	Z3301	C20	
C2019	E17	C2228	I9	C2826	D8	C7501	H5	D3000	C7	L7523	G3	R1519	B16	R3304	G10	Z6200	C12	
C2020	E17	C2231	I11	C2827	D7	C7502	H5	D3201	C15	L7524	G5	R1520	C16	R3305	G10	Z7521	G3	
C2021	E18	C2232	I9	C2828	G5	C7503	H3	D3300	E12	L7525	G3	R1521	C16	R3306	E12	Z7523	H4	
C2022	E17	C2235	H9	C2829	D6	C7504	H3	D6000	G13	L7540	E4	R1522	B16	R6010	G11	Z7540	E3	
C2023	E16	C2236	G9	C2830	G6	C7505	H3	<b>F</b>	L7541	E2	R1524	C17	R6300	I14	Z7541	E3		
C2071	F3	C2237	I11	C2850	I7	C7506	H3	F2000	F20	L7560	B4	R1525	B18	R6500	F20	Z7542	E4	
C2072	E3	C2238	I11	C2852	H11	C7507	H3	<b>G</b>	L7561	C4	R2000	F19	R7500	G3	Z7543	G4		
C2073	F3	C2303	G10	C3000	C8	C7508	H4	G6200	C12	L7562	B2	R2010	D19	R7501	H5	Z7544	G4	
C2074	F3	C2304	H10	C3001	C8	C7509	C2	G7500	H4	L7563	G3	R2011	E19	R7502	H5			
C2075	F3	C2307	H9	C3002	C5	C7510	H4	<b>L</b>	L7575	F5	R2013	F20	R7504	G3				

